

## „The Internet of Things at Home,,

by Einar Sneve Martinussen, Una Bjerkan Heimstad  
& Ingeborg Marie Dehs Thomas

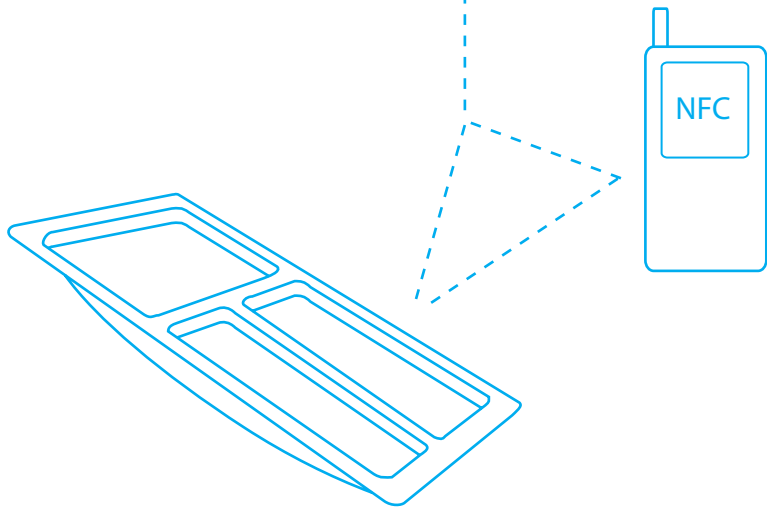

**We have created a service that connects the Home to a layer of digital information through our use of things and objects. We have focused on the Special Things; the extra nice objects that have an elevated significance in our everyday life. connection between the physical and a layer of additional information digital services.**

We have tracked these Things backwards to when they were bought and when they were brought into the home. We have looked at their stories and the every Where are they placed? How does one make metal wish-lists, and what does this do to the things we buy? How does things travel within the home, and within our attention? When are new things no longer new things? Where does nice labels and extra buttons go when you by a new shirt? And where do they end up? Do you ever visit the websites printed on the lables? When do you visit these sites? When do you acquire additional information about your things? What makes you buy a pair of jeans, and what makes you buy your next pair of jeans?

How is buying nice things and placing them in your home different from stereotype shopping? We think there might be a cultural difference. Buying nice Things from nice people in nice shops builds a stronger emotive/personal relationship to the things we choose to acquire. Buying our Things this way also adds us to the social contexts and communities surrounding the brands, products and stores.

What helps building these personal relationships? (Stories, rituals, contexts, social belonging, communities, cult?) How can we enhance this relationship by adding a layer of digital information? How can this layer be embedded within already existing rituals? NFC-interaction in the home?

We have based our research on analyzes, photos and mapping within our homes, and have looked at some specialized brands and (indie)shops that offer user experience out of the ordinary. We find that our ideas are easiest to stretch when working with the subcultural and those with special interests, but that they can be applied on a larger scale.

What we are working towards is a sketch for "The Internet of Things at Home".

Our concept uses NFC-interactions and RFID technology embedded in the use of Things and the rituals surrounding them. We have look at the existing touchpoints of the Home and used these as the connection between the physical and a layer of additional information digital services.

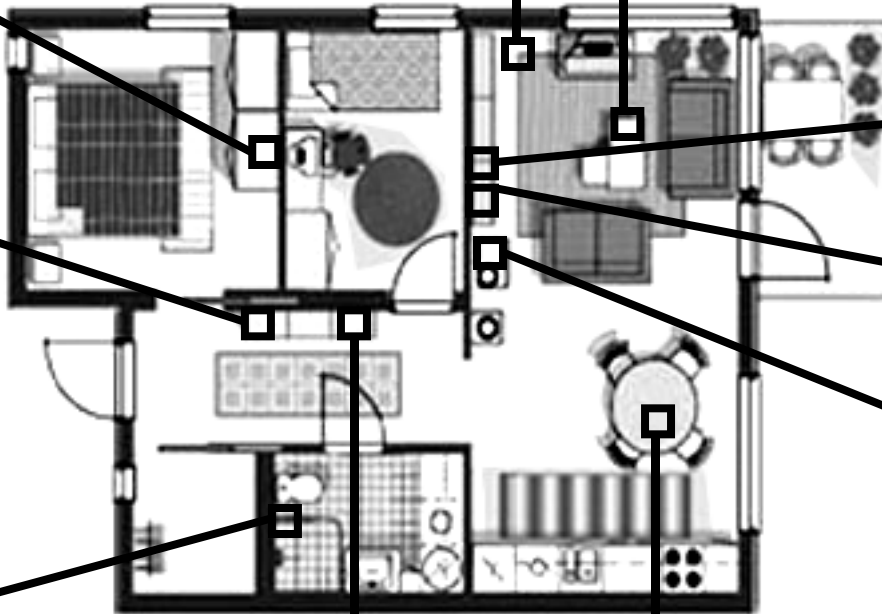

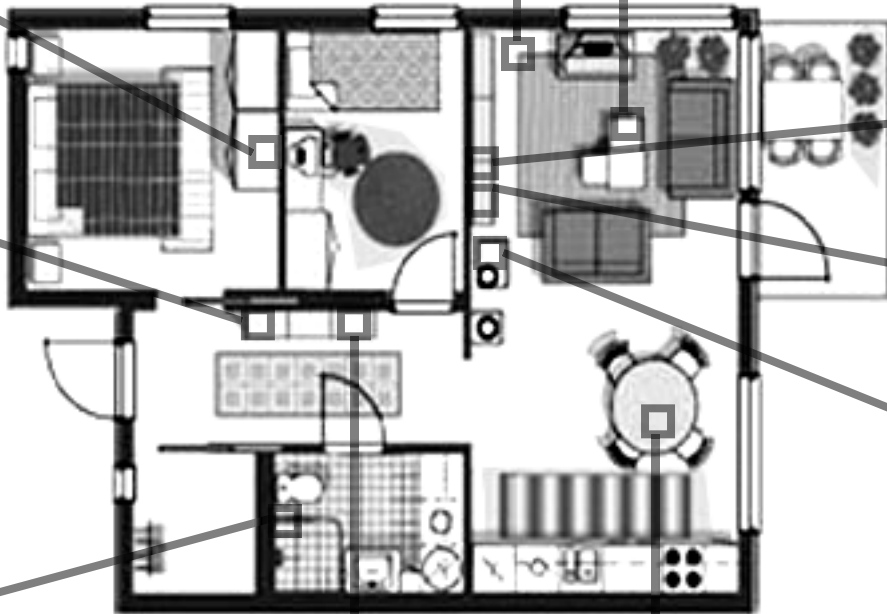

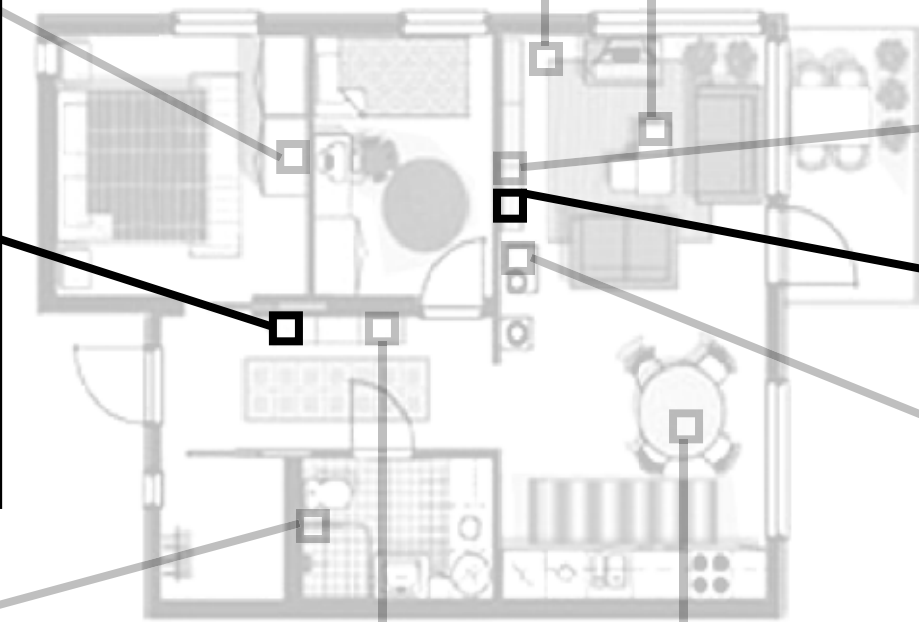

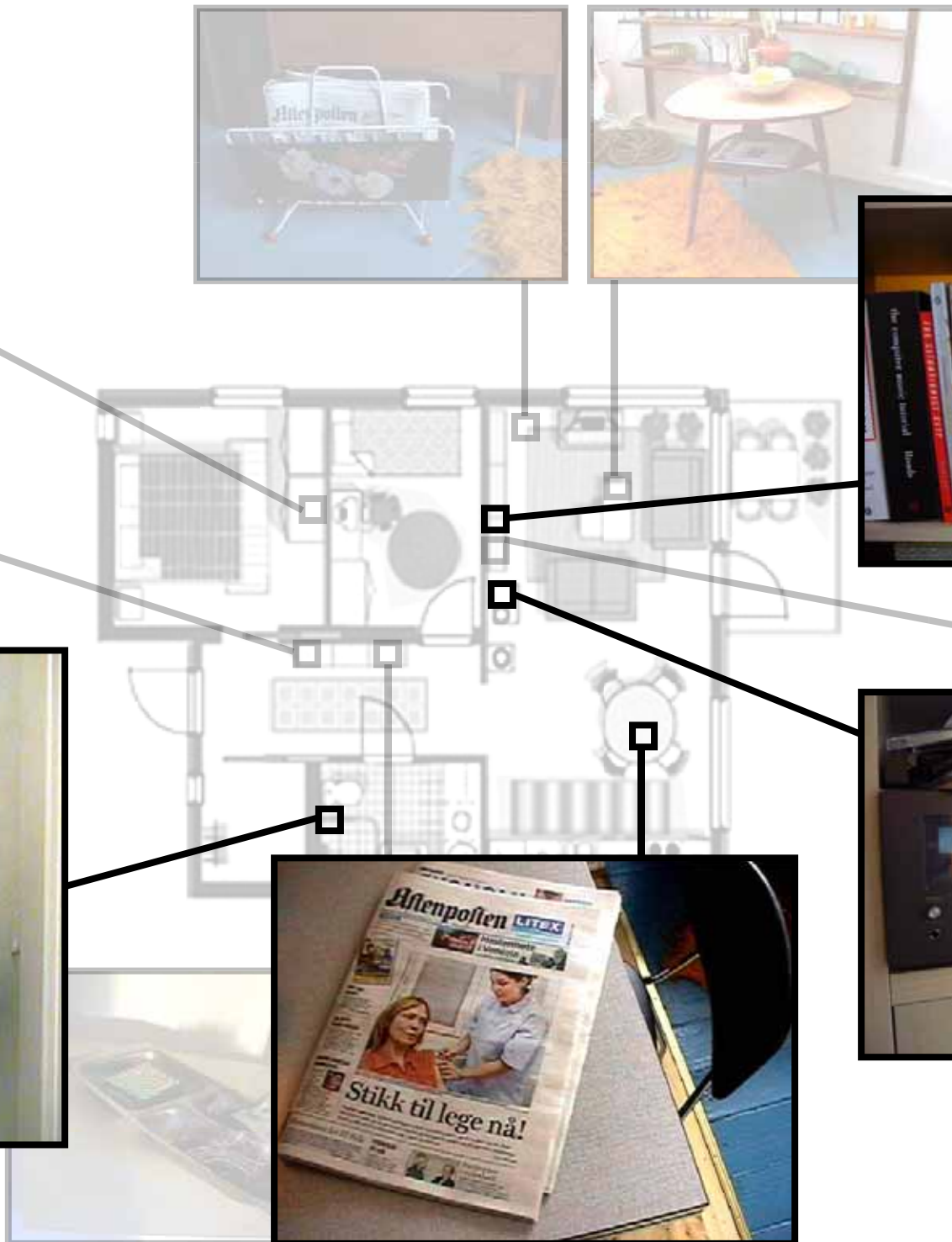

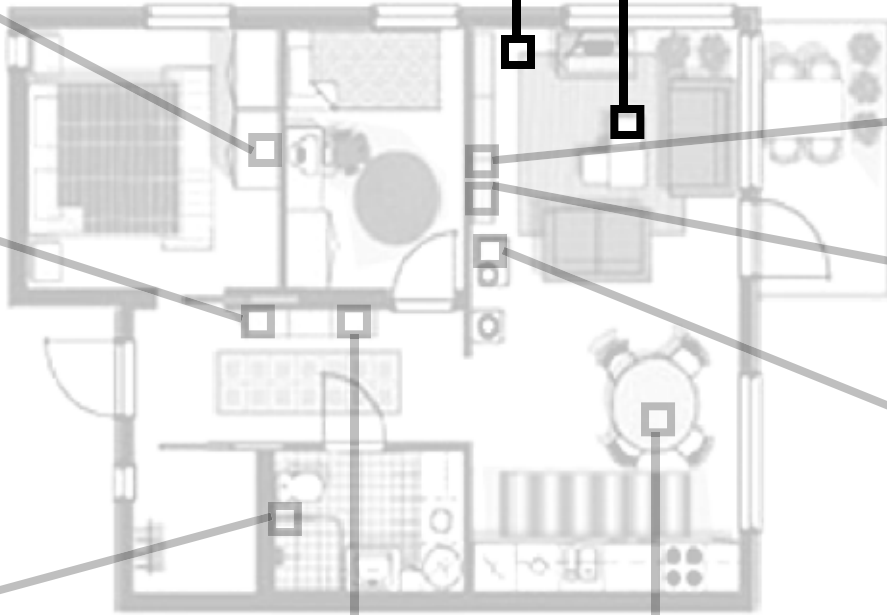

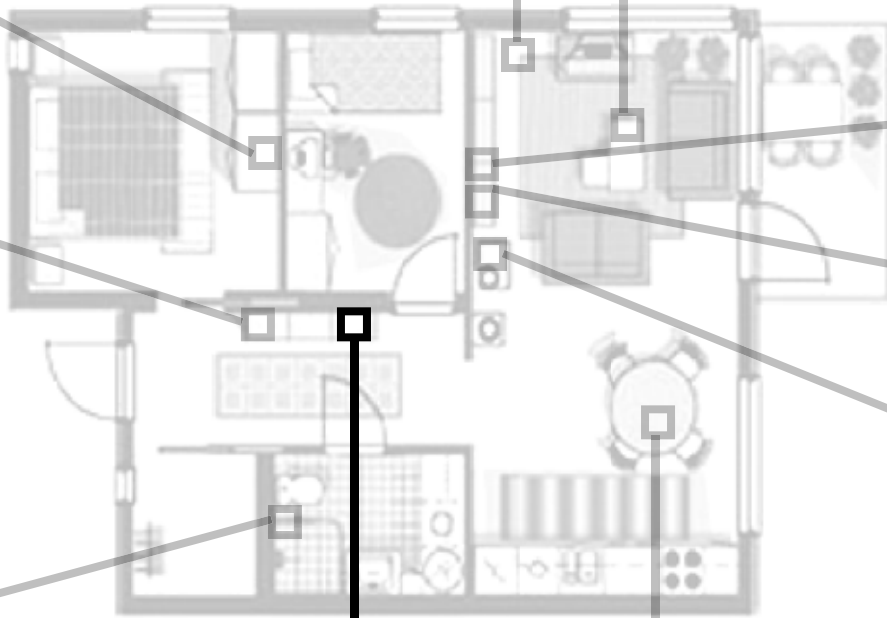

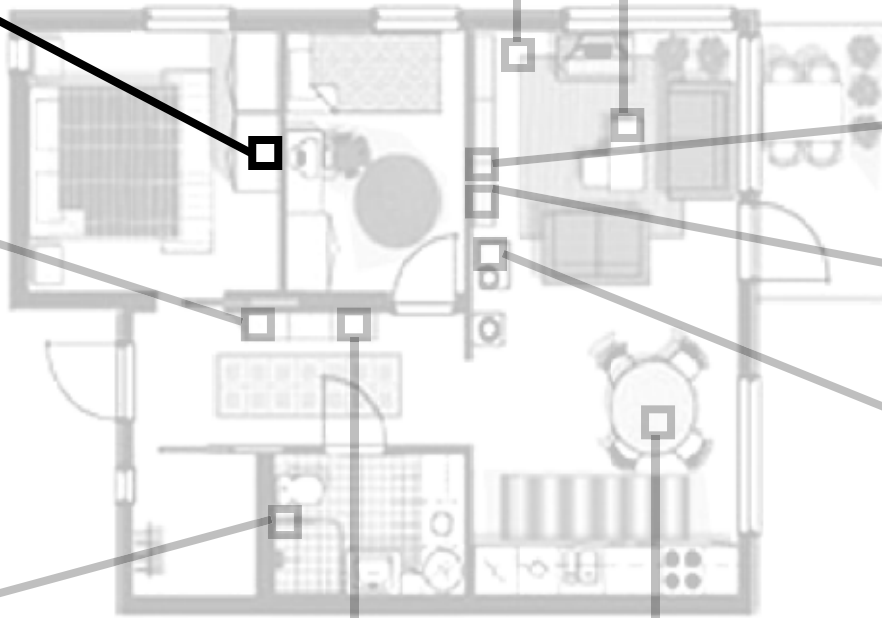

Buying Neat Jeans - Analog / Digital

Thinking about buying a new pair of jeans...



Discovering the shop



Adventuring



Trying on jeans, discussing them with the owner



Purchasing

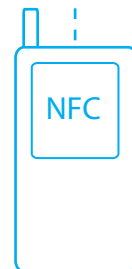
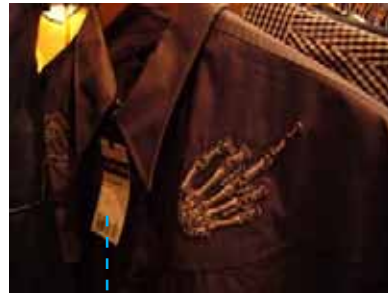

Adding neat shirt to digital wish-list by reading NFC-label.

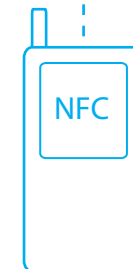



Period of doubt!

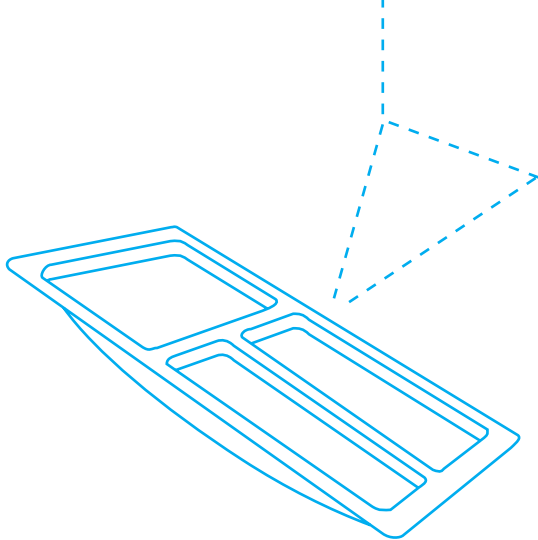

Reading the RFID-comb with the NFC-phone. Placing the phone in the NFC-bowl to transfer the shop/comb to the digital archive. Downloads the shop-presentation and let you watch it on your TV.



The final decision; removing labels

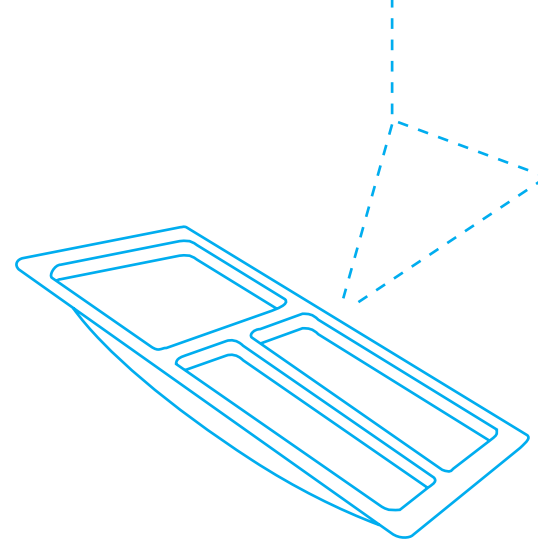

When you finally have decided that the jeans are a good buy, you read the label with the phone. You put the phone in the bowl and register your jeans in your digital archive.

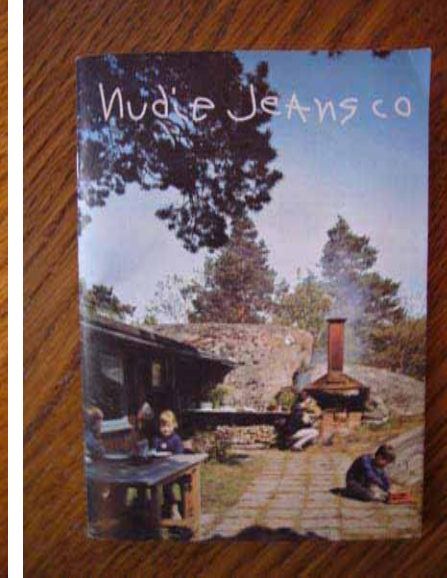



Party invite along with the jeans. Reminder through your calender-software or Social Network Application



You proudly live with your jeans.



SMS: You've had the jeans for 6 months. Wash them now! (inside out, 60\*, no-bleach)



You buy your next pair of jeans at the same shop...



Your digital archive of things you own and care about is the input for services related to what you own.

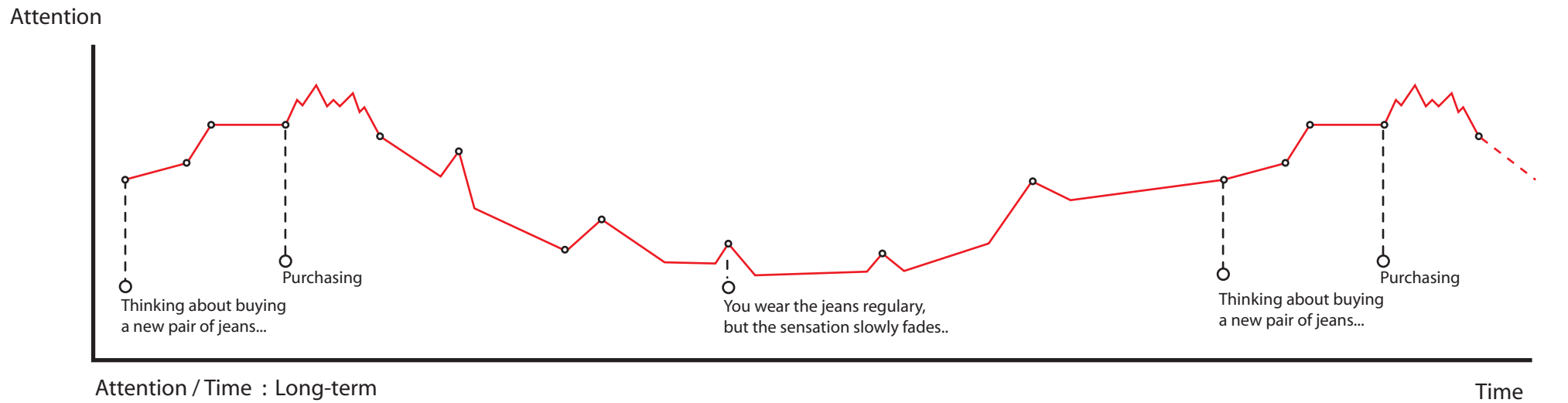
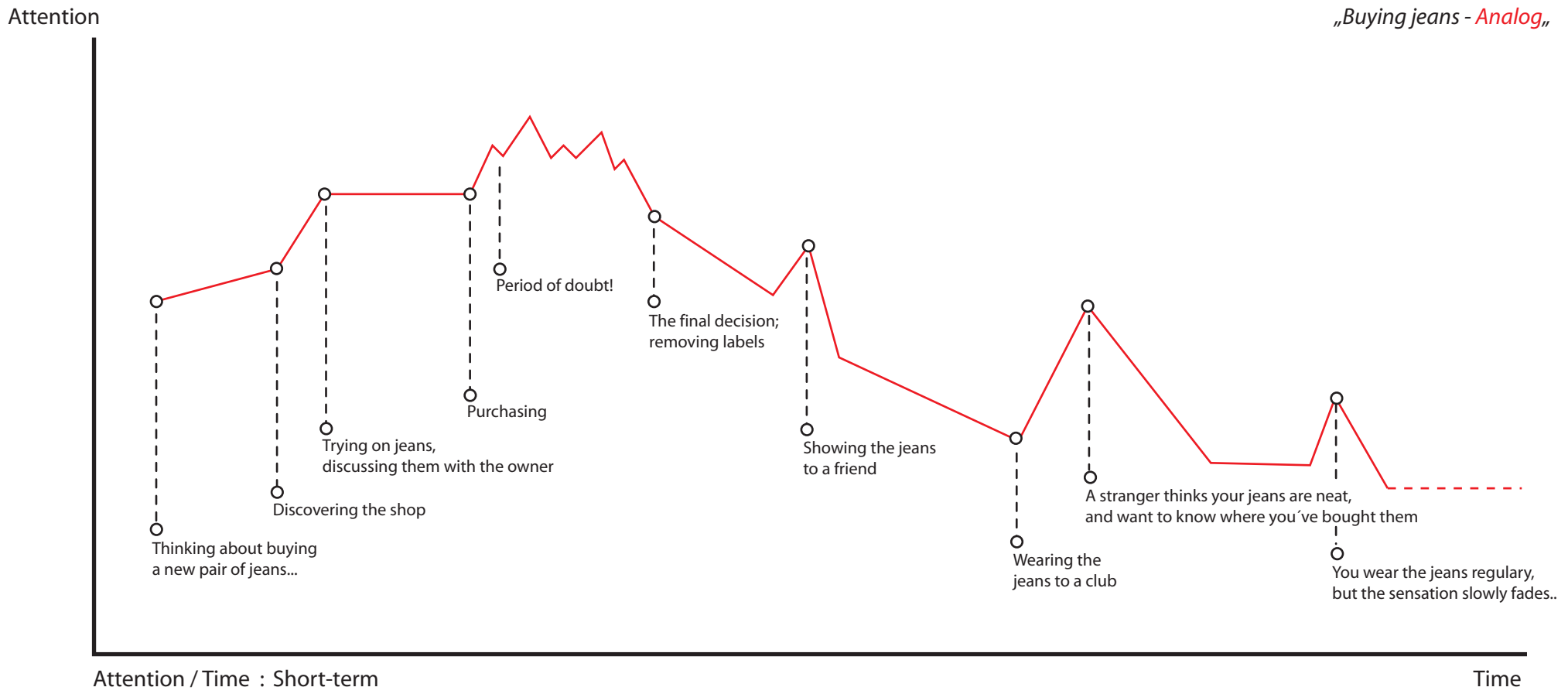

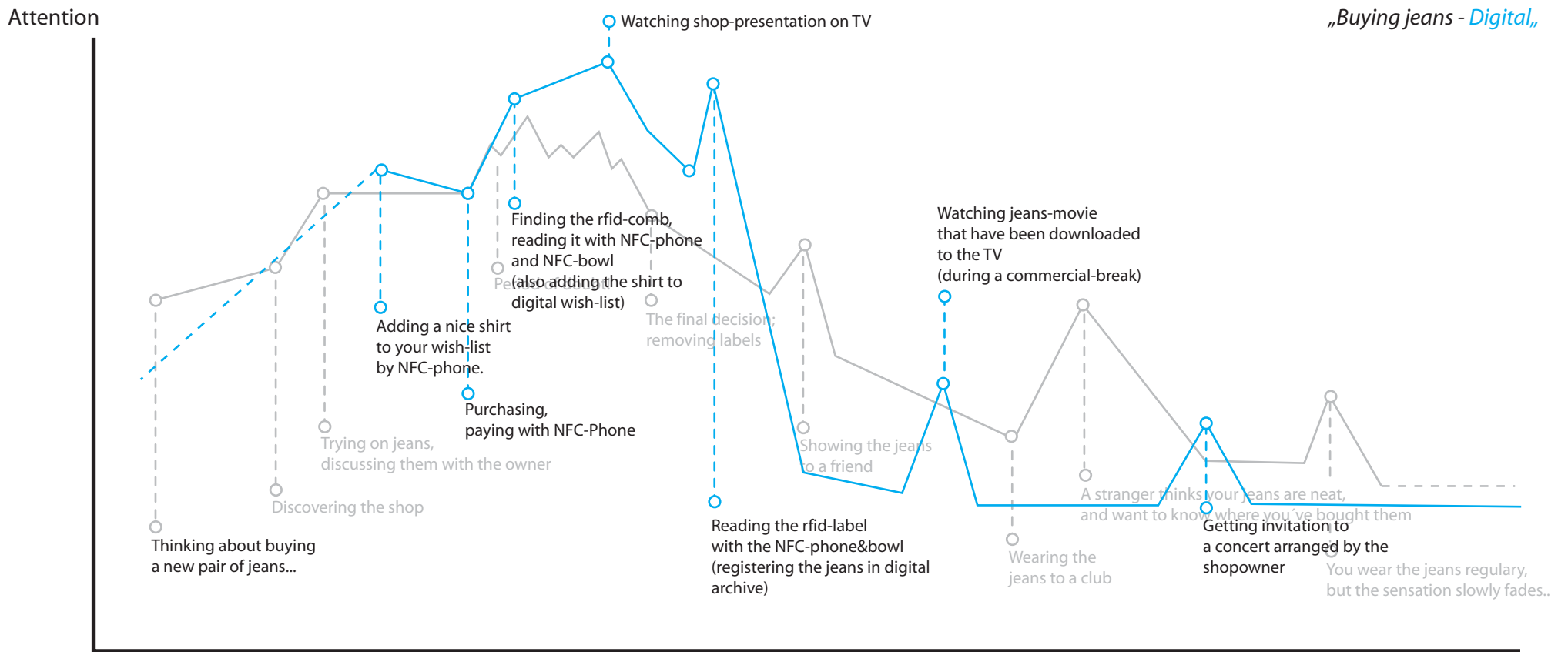

Attention / Time : Short-term

Time

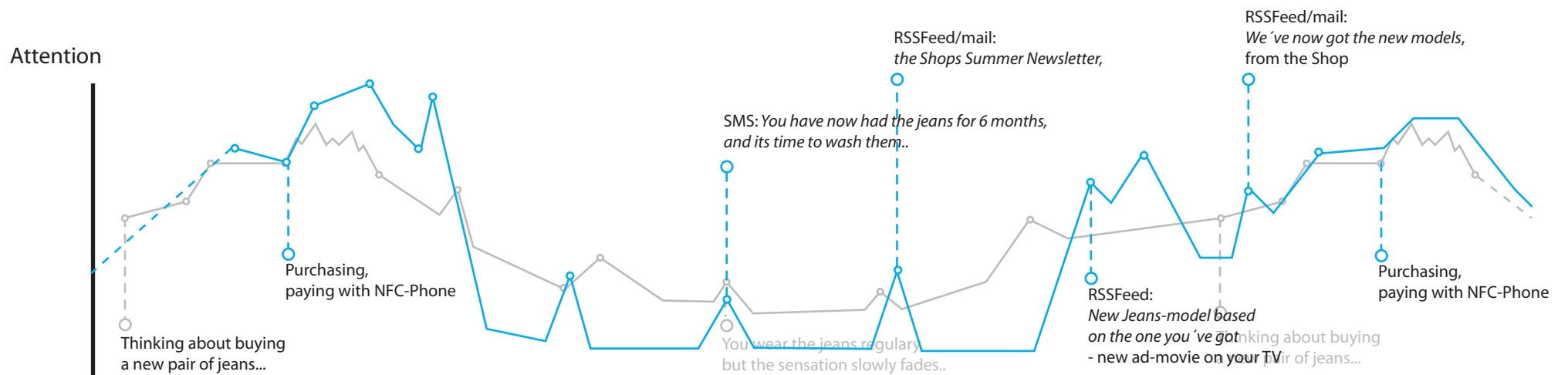

Attention / Time : Long-term

Time

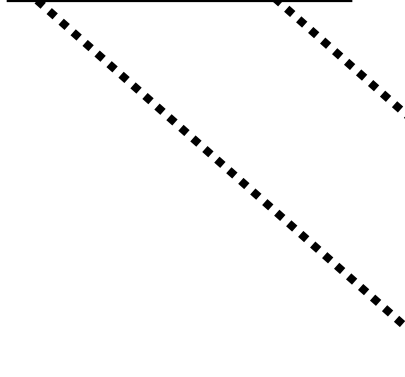
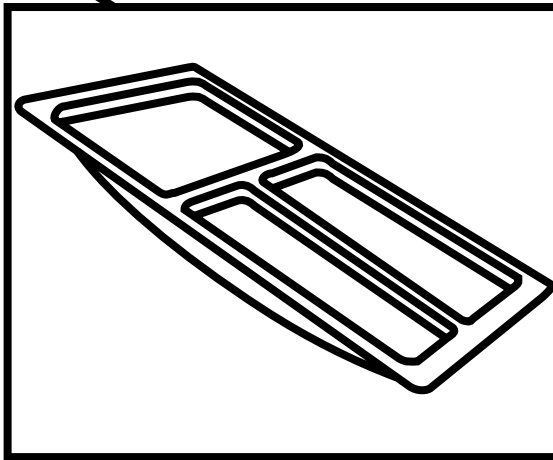
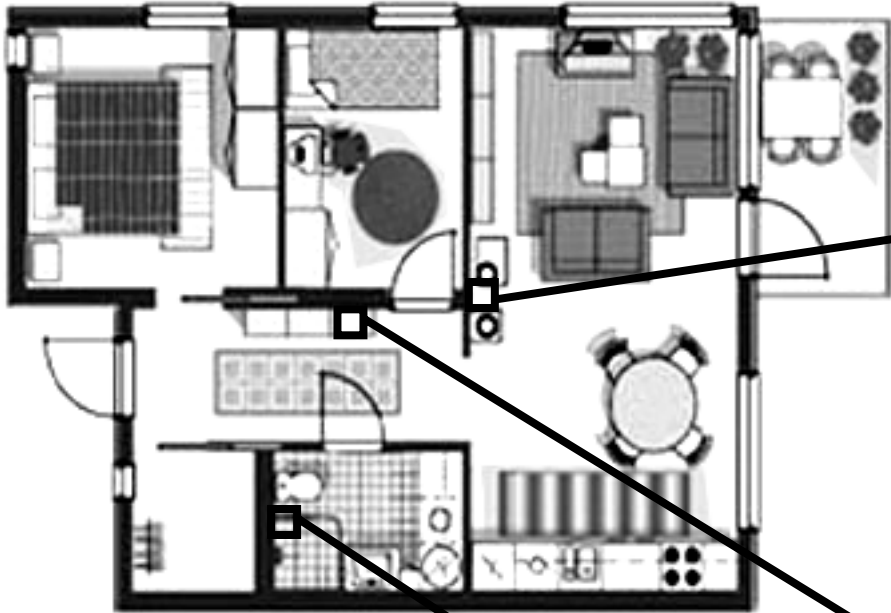

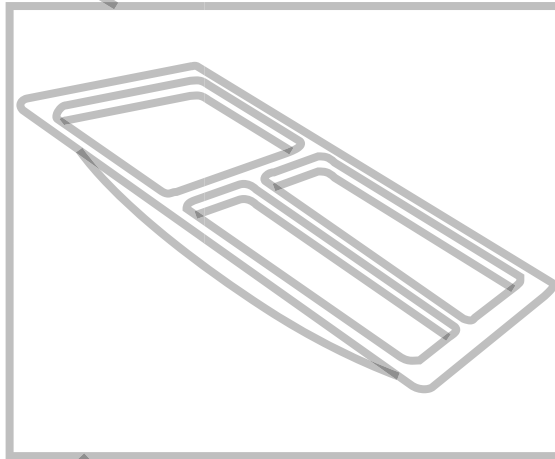
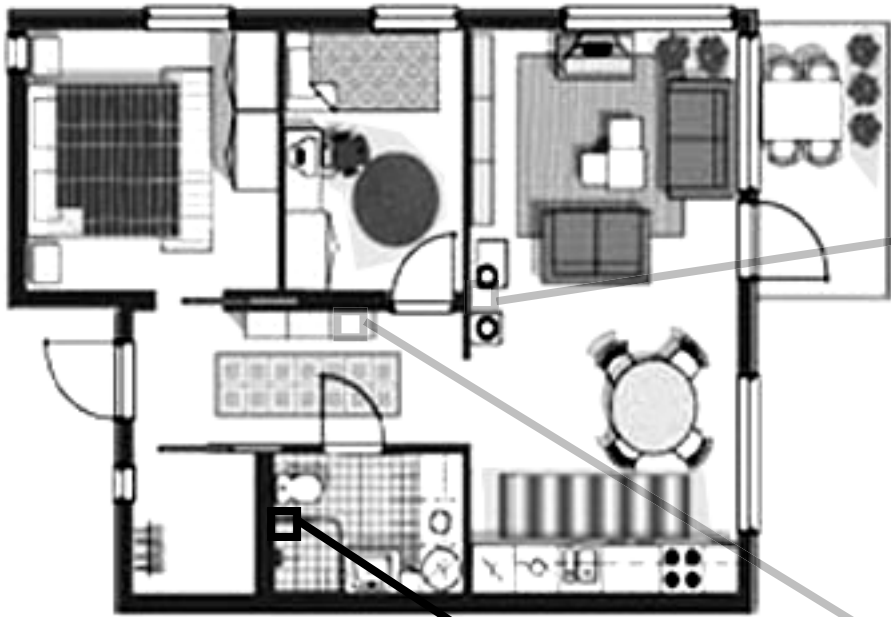

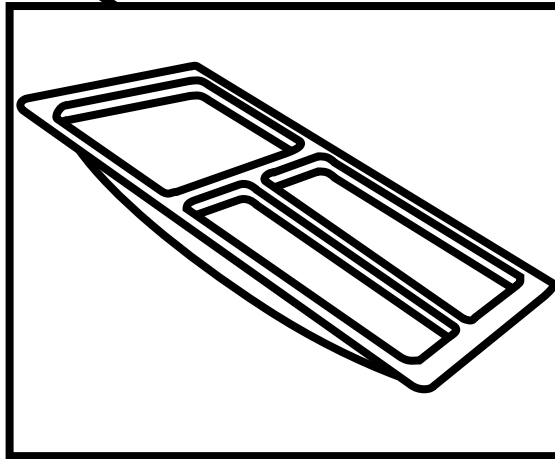
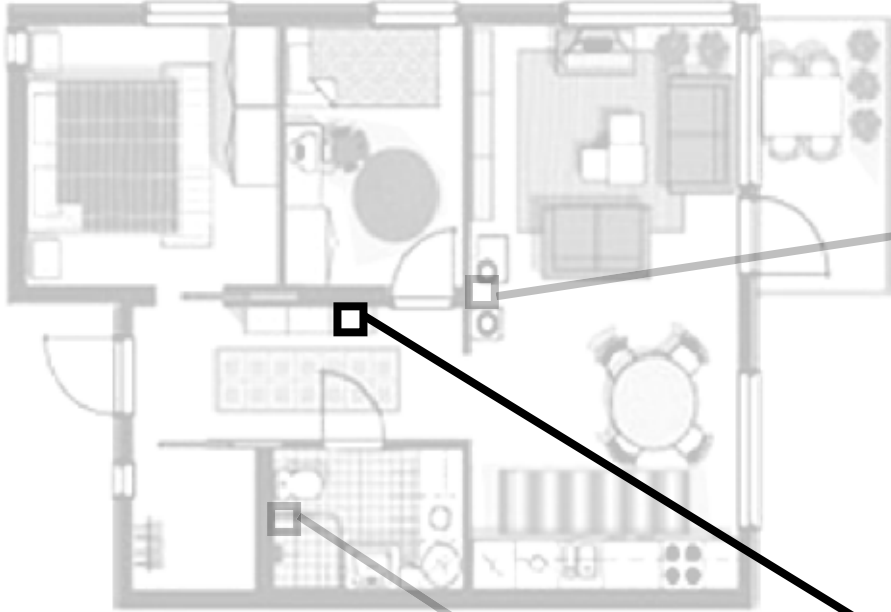

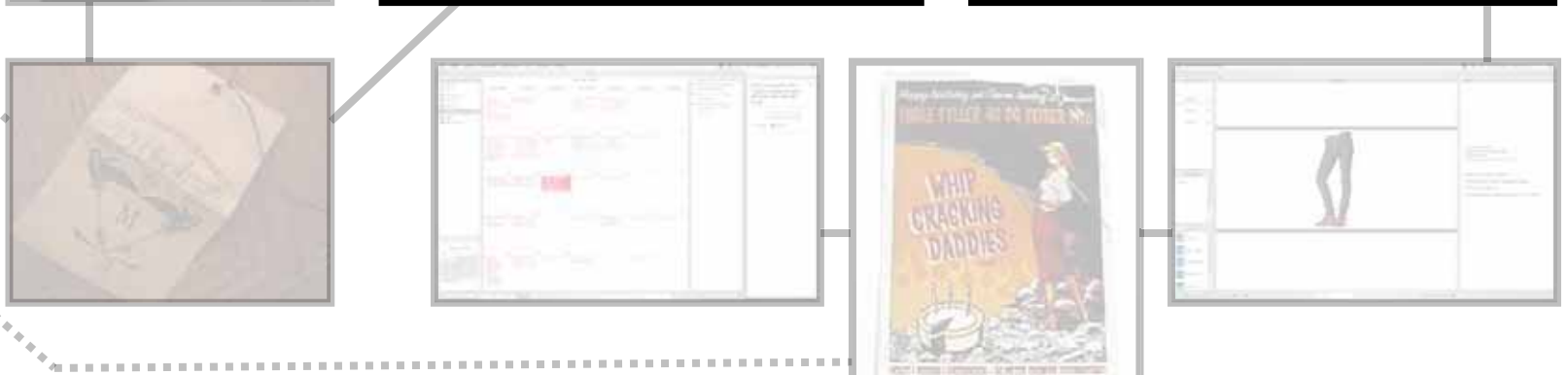
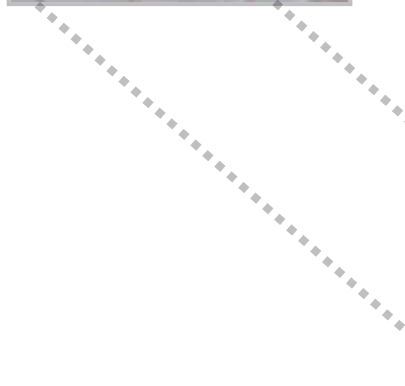
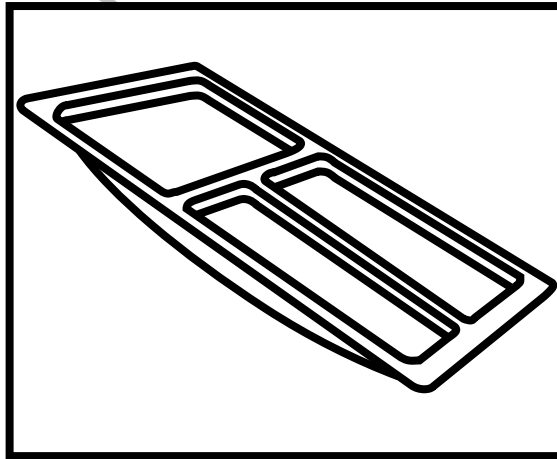
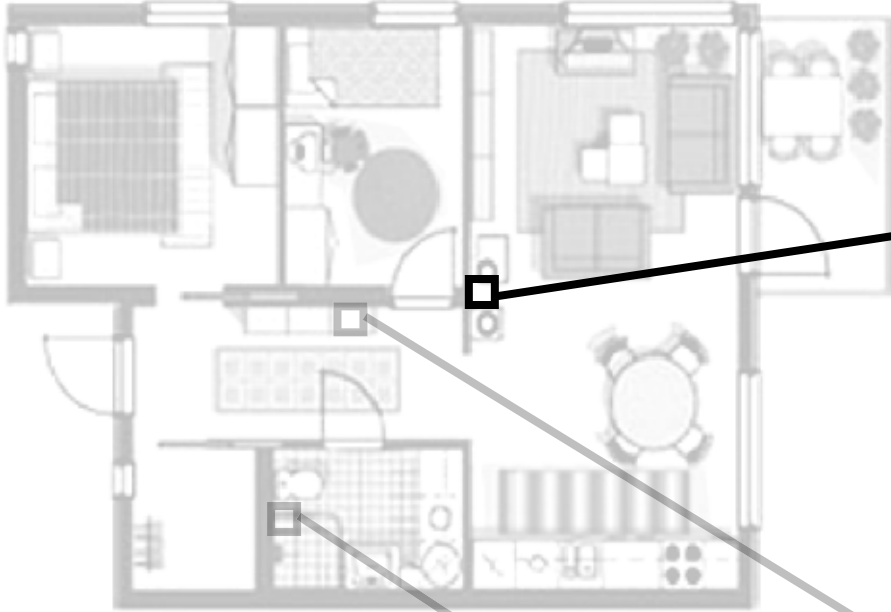

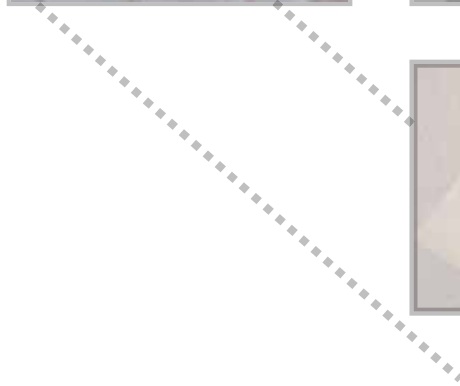
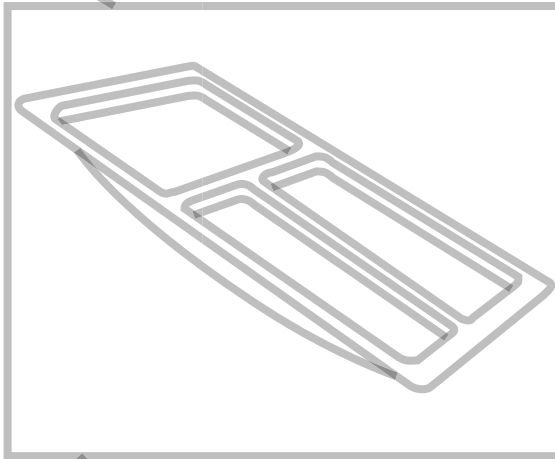

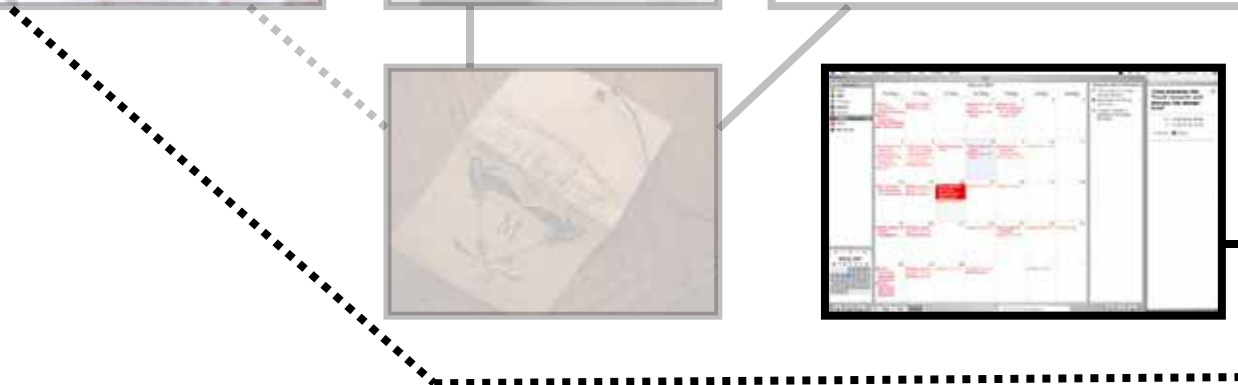
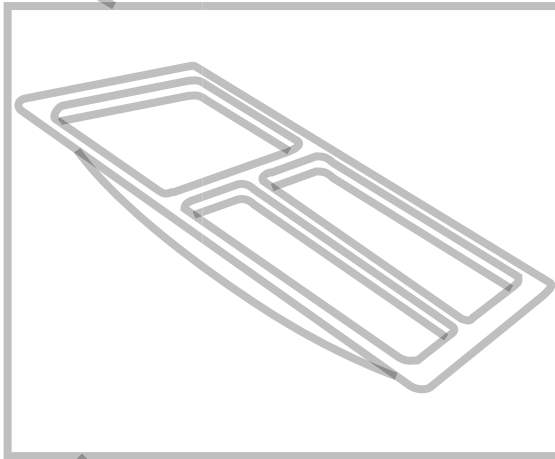
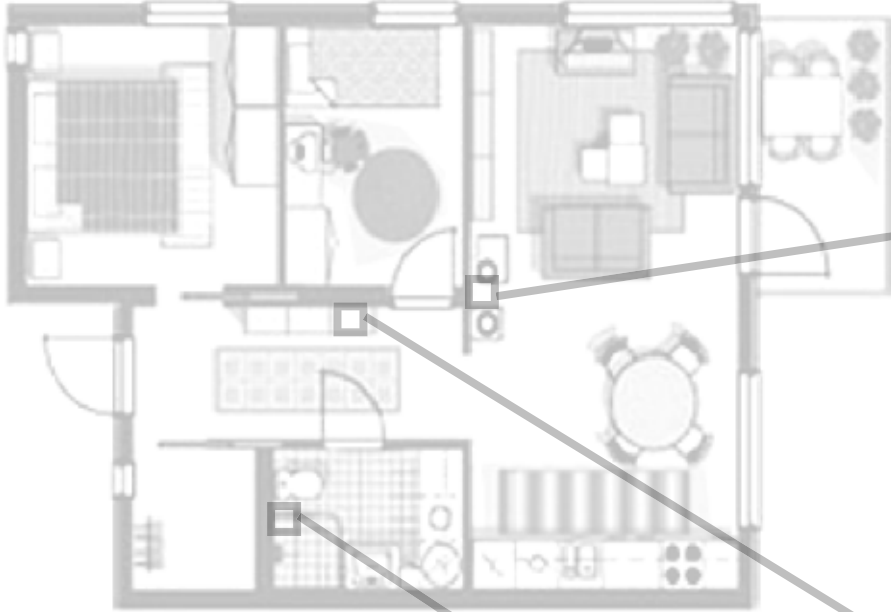

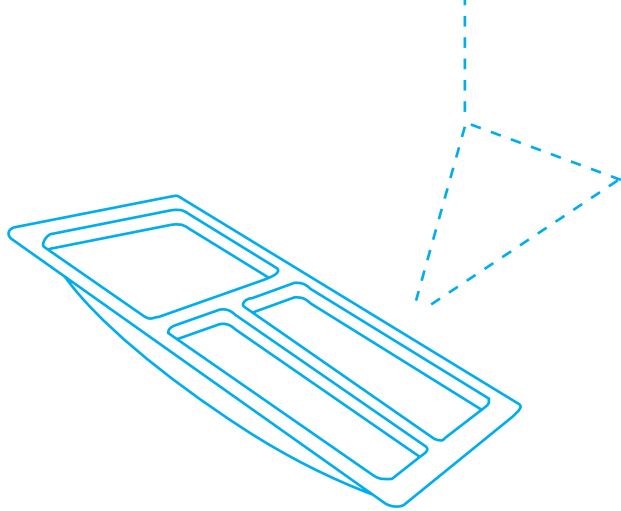

The Ritual of Placement

## SUMMARY

1 – EMOTIVE; rituals, confirmation, “the good purchase” ++

2 – SOCIAL; community, stories and artefacts, belonging ++

3 – Utility; Library, SNA, LastFM-like services, warranty, registration ++

## Keywords:

- the Coffeetable-effect
- Periphery vs Center
- Rituals in Everyday Life
- the Psychogeography of Things
- the Hidden Track
- Personal Dialogs
- Layers